

# SMOKE & COMBINATION FIRE SMOKE DAMPERS

**SD-30 SMOKE DAMPER**

**FSD-30 FIRE & SMOKE DAMPER**

**UL555 1 ½ HOUR FIRE RATING**

**UL555S LEAKAGE CLASS 1**



**IRAN**  
**IGGC**

IGC International Group

# SD/FSD-30 DESIGN & CONSTRUCTION FEATURES



## Description

Model SD/FSD-30 is a smoke and combination fire smoke damper designed with 3V style blades and qualified for closure in static and dynamic systems with velocities to 2,000 fpm and pressures to 4" w. g. and installed vertically.

## Construction

Frame:  
5" x 16 Ga., roll formed galvanized steel hat-section with stake corners with integral bracing

Blades:  
16 Ga., roll formed galvanized steel, 3-V groove style

Linkage:  
Plated steel, concealed in jamb

Bearings:  
Bronze, pressed into frame

Jamb Seals:  
Stainless steel, flexible metal compression type

Blade Seals:  
Silicone edge type 350°F

Closure Device:  
Electric Fusible Link 165°F

## Optional Features

Factory Sleeves and Transitions  
Actuators: Electric 24 V, 230 V  
Open Close Indication Switch (Integral Auxiliary Switch)  
Manual Reset Switch Retaining Angles

## RATINGS

(In Accordance with)  
UL555 Fire Resistance Rating: 1 ½ Hour  
UL555S Leakage: Class I  
Maximum Velocity: 2000 fpm  
Maximum Pressure: 4 in. w.g.  
Maximum Temperature: 350°F

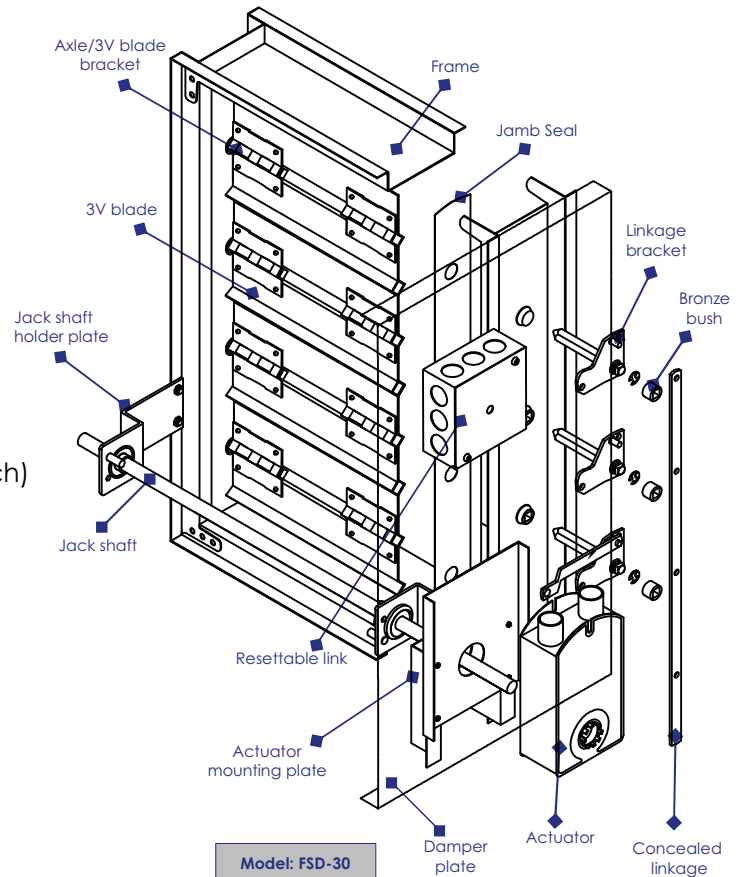

# SD/FSD-30 DESIGN & CONSTRUCTION FEATURES



## Frame Reinforced Corner Design

The Tog-L-Lock design, reinforced corner is incorporated into IGC combination Fire Smoke Damper frame. It provides higher structural rigidity than many competitor's welded frames. The design ensures that every frame has square corners, helping prevent blades from binding on the jamb seals and making damper operation much smoother with less torque.

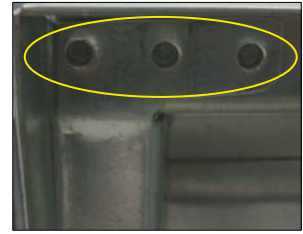

## Maximize Free Area and Minimize Pressure Drop

3V Blade/Variable size design uses a combination of four 3V blade sizes 4, 5, 6, 7 and 8 inch (102, 127, 152, 178 and 203 mm) to maximize the free area at any given height and minimize pressure drop. The 3V blade design also allows for consistent operating characteristics regardless of airflow direction. Traditional damper design utilize only one blade width usually 6 inch (152mm), which reduces manufacturing costs, but compromises the dampers performance and cause of high pressure drop in the whole ducting system.

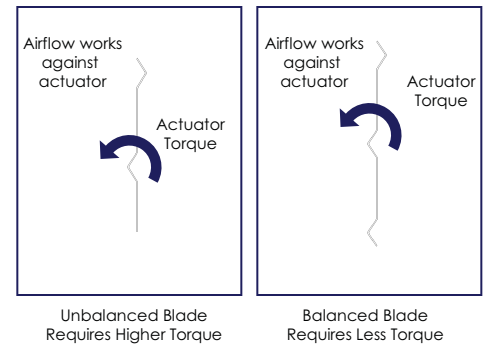

## Sleeve Standard Details

Damper Sizes	Minimum Sleeve Size
203 x 203 to 254 x 254 (8" x 8" to 10" x 10")	559 (22")
254 x 254 to 304 x 304 (10" x 10" to 12" x 12")	508 (20")
304 x 304 to 457 x 457 (12" x 12" to 18" x 18")	457 (18")
457 x 457 to 914 x 914 (18" x 18" to 36" x 36")	330 (13")

**Note:** Other non-standard sleeves also available. Please consult IGC for more details.

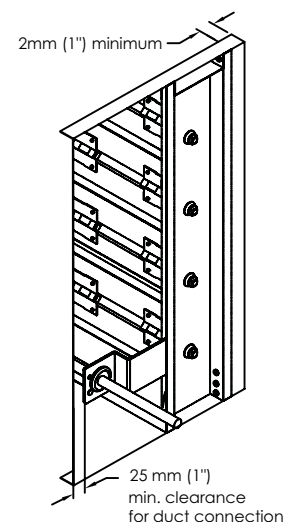
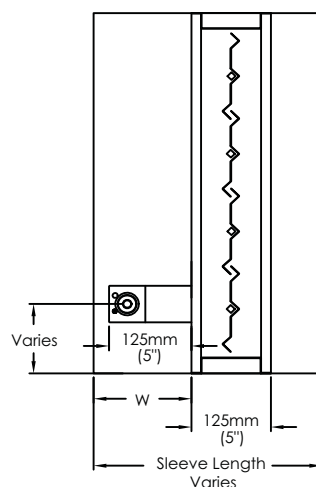
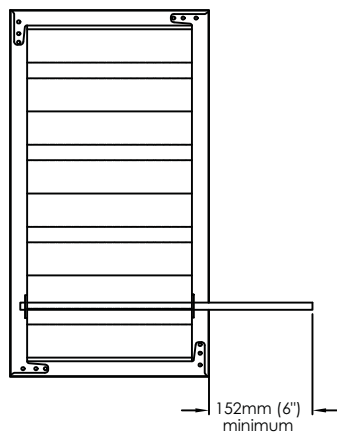

# SD/FSD-30 TRANSITIONS AND SIZE LIMITATIONS



## Transitions

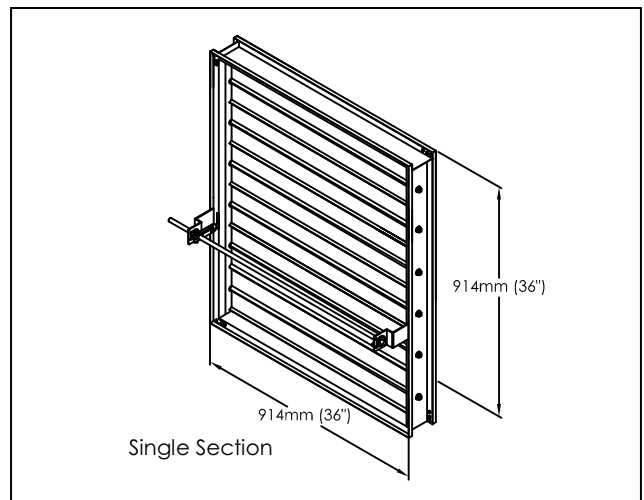
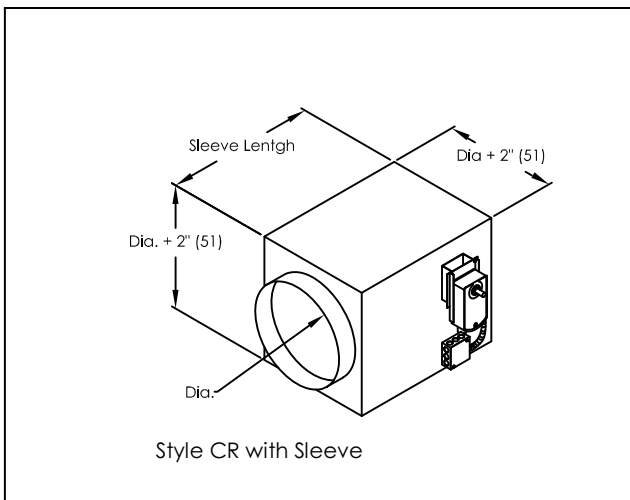
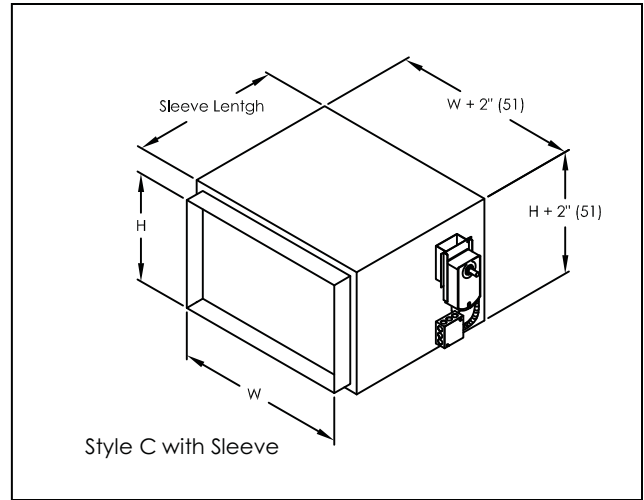
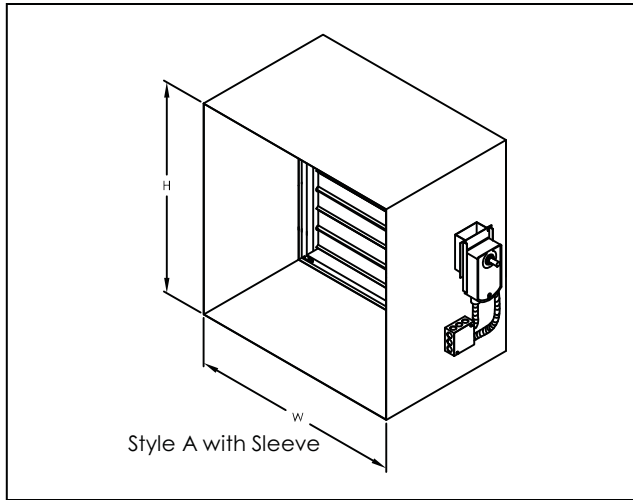

## Damper Sizes

VERTICAL SINGLE SECTION SIZE W X H, in (mm)	
MINIMUM	8" x 8" (203 x 203)
MAXIMUM	36" x 36" (914 x 914)

# SD/FSD-30 OPTIONS AND ACCESSORIES INSTALLATION



## Clearances required between fire damper sleeves and wall openings

Smoke and Fire Smoke damper and sleeve assemblies expand during periods of intense heat. Therefore, it is essential that openings in walls be larger than the fire/smoke damper and sleeve assembly to allow for this expansion. Minimum clearances required between the outside of fire damper sleeve assemblies and wall openings are:

- Galvanized steel fire dampers and sleeves: 1/8 in. per foot (3mm per 0.3 m) of damper width and 1/8 in. per foot (3mm per 0.3 m) height with a minimum clearance of 1/4 in. (6mm), maximum of 1 1/2 in. (38mm).

Recommended clearances, for width and/or height dimensions of:

1) 36 in. (914mm) or less: 1/2 in. (13mm) clearance

These are total clearances (ignoring fastener heads) and do not need to be equally spaced around the damper.

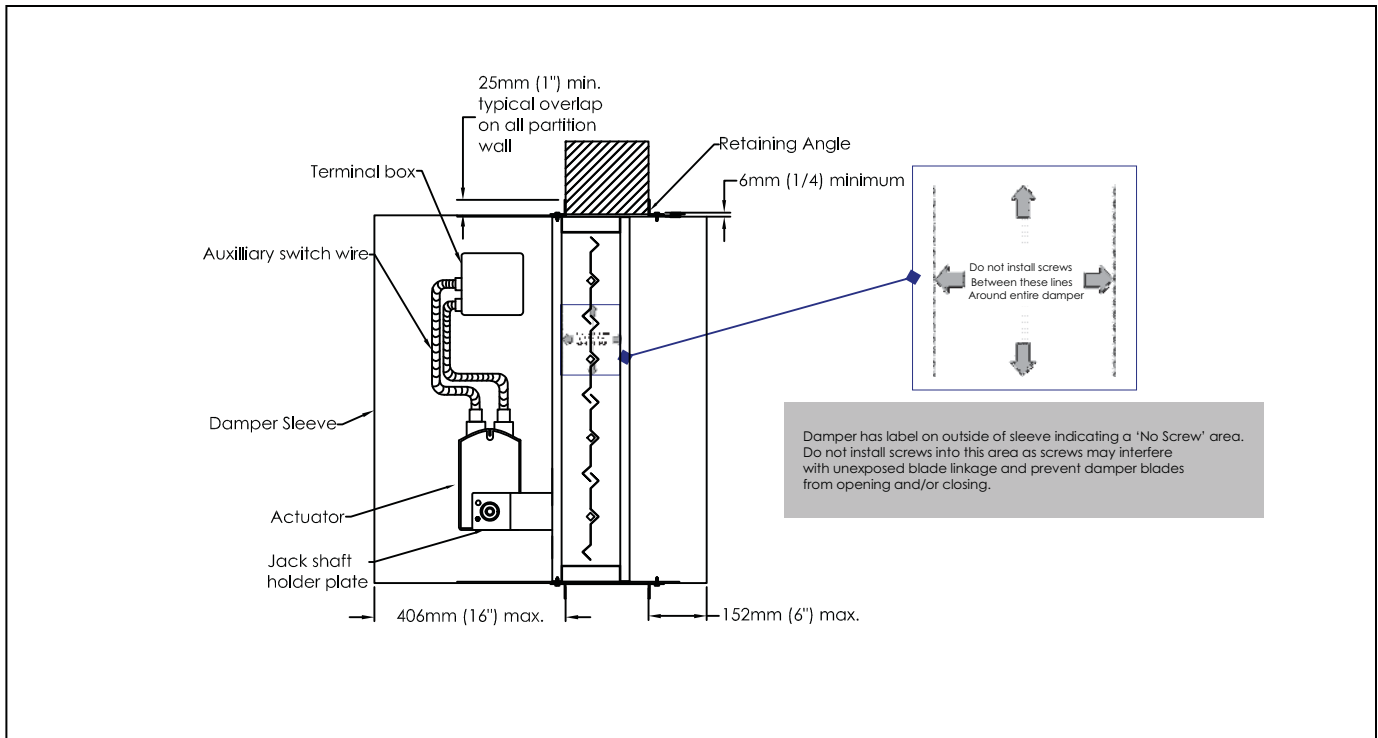

## Sleeve Length and Wall Thickness

The sleeve may extend a maximum of 16 in. (406 mm) beyond the wall on the actuator side of the damper and a maximum of 6 in. on the opposite side.

Recommended sleeve lengths for various wall thickness are:

WALL THICKNESS DIMENSION (Tw)	SLEEVE LENGTH DIMENSION (L)
4 -6 in. (102mm -152mm)	16 in. (406mm)
7 -10 in. (178mm -254mm)	21 in. (533mm)
11 -13 in. (279mm -330mm)	24 in. (610mm)

# SD/FSD-30 OPTIONS AND ACCESSORIES INSTALLATION



## Duct to Sleeve Connections

Dampers are supplied with sleeves and actuators from the factory and can be installed without the need for additional field installed sleeves. Gauge of factory furnished sleeve determines the type of duct to sleeve connections required (see table below). Any duct connection other than the breakaway connections described on page 6 are considered rigid. Factory furnished duct collars, type R and O, are also considered breakaway (see Fig. 1).

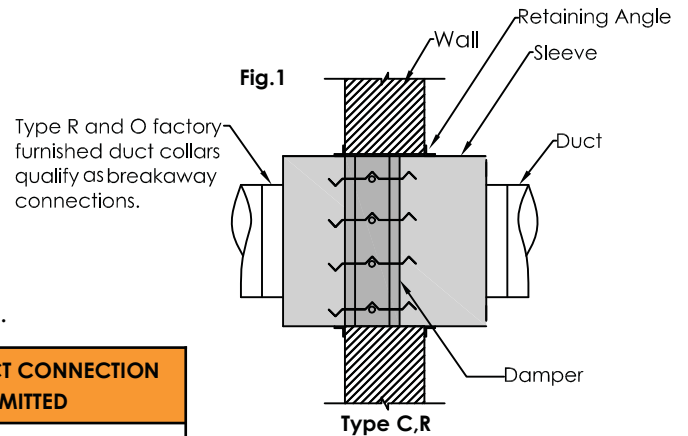

SLEEVE GAUGE	DUCT DIMENSION	TYPE OF DUCT CONNECTION PERMITTED
14 ga. – 10 ga. [2mm – 3.5mm]	All duct sizes	Rigid or Breakaway
16 ga. [1.5mm]	36 in. (914mm) max. width 24 in. (610mm) max. height 24 in. (610mm) diameter	Rigid or Breakaway
16 ga. [1.5mm]	All duct sizes	Breakaway only
UL Standard 555 requires that connecting ducts shall not be continuous and shall terminate at the sleeve.		

## Securing The Damper/Sleeve Assembly to Wall Openings

Damper/sleeve assemblies must be installed in wall openings using retaining angles on as described below:

-Retaining angles for 1 ½ hour rated dampers with a width and height of 36 in. (914mm) or less must be a minimum of 20 ga. (1mm). The leg of the retaining angle on the damper sleeve shall be a minimum of 1 ½ in. (32mm). The leg of the retaining angle on the wall shall be long enough to cover the annular space and overlap the wall by a minimum of 1 in. (25mm)

-Retaining angles must be attached to the damper using one or more of the following methods of attachment (refer to Label on outside of sleeve for “No Screw” area):

- o Tack or spot welds
- o #10 (3/4 in. [19mm] max.) sheet metal screws
- o 1/4 in. (6mm) bolts and nuts
- o 3/16 in. (5mm) steel pop rivets

A minimum of two connections per side, top, and bottom, 6 in. (152mm) O.C. maximum for openings of 36 in. W x 36 in. H (914mm x 914mm) and less.

The angles must be attached to all 4 sides of the sleeve. Ensure that attachment device does not interfere with the operation of the damper and the free movement of the damper blades. The angles need not be attached to each other at the corners. Do not secure the retaining angle to the fire separation (see Fig. 2).

- Retaining angles should not be fastened to the wall material. The angles should only sandwich the wall and allow for damper expansion during periods of intense heat.

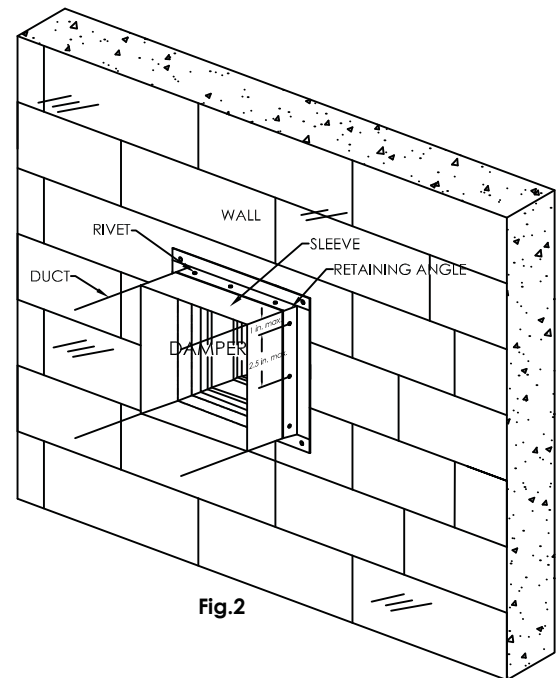

# SD/FSD-30 OPTIONS AND ACCESSORIES INSTALLATION



## Connecting Ducts to Fire Damper Sleeve

Any duct connection other than breakaway is considered rigid. The connections shown are considered breakaway. Factory furnished duct collars on type R and CR fire dampers are also considered breakaway.

### Duct-Sleeve Connections

#### Traditional Breakaway Style Transverse Joints

Transverse joints illustrated have always been approved as breakaway connections. SMACNA testing has also approved the following variations as breakaway connections. Breakaway connections shall have no more than two #10 (4.8mm diameter) sheet metal screws on each side and on the bottom located in the center of the slip pocket and shall penetrate both sides of the slip pocket (applicable to the Plain "S" Slip and Hemmed "S" Joint). Transverse joint can be applied as top and bottom joints with Drive Slip – side joints in duct heights up to 20 in. (508mm)

Plain "S" Slip	
Drive Slip Joint	
Hemmed "S" Slip Joint	

## AIR PERFORMANCE DATA

### Pressure Drop:

Pressure drop testing was conducted in accordance with AMCA Standard 500-D

**Test Figure 5.3** (In accordance with AMCA Standard). AMCA Test Figure 5.3 illustrates a fully ducted damper. Where entrance and exit losses are minimized by straight duct runs upstream and downstream of the damper.

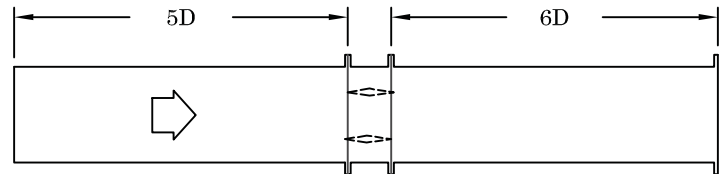
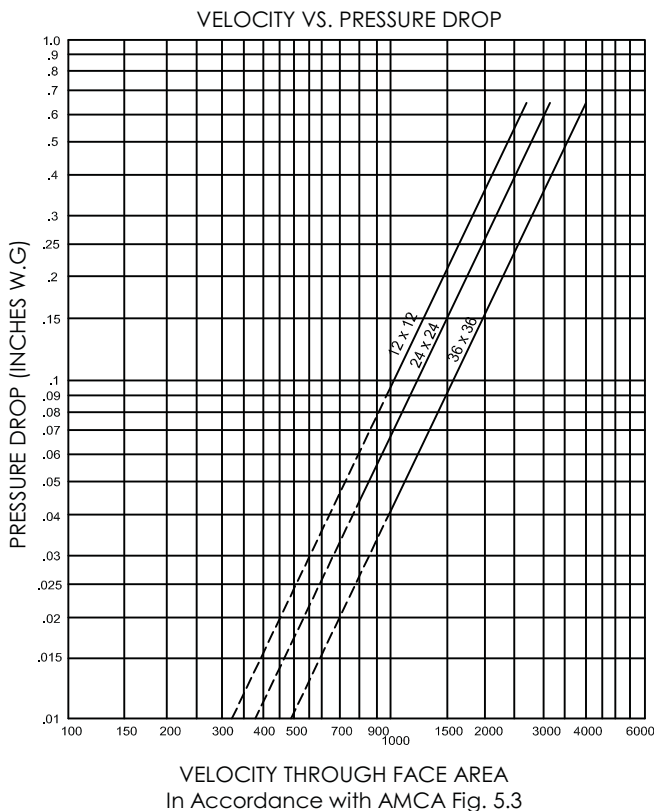
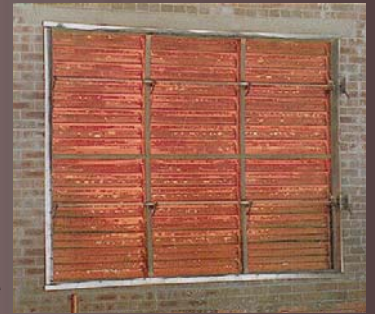

Fig. 5.3

## TEST STANDARDS & CERTIFICATIONS

### UL555

This test standard governs fire dampers which are intended for use where air ducts penetrate or terminate at openings in walls or partitions, in air transfer openings in partitions, and where air ducts extend through floors as specified in the Standard for installation of Air-Conditioning and Ventilating Systems, NFPA 90A. In a fire emergency the damper is designed to close and prevent the spread of fire from one side of the wall or partition to the other. Side testing includes cycling, salt spray, dust loading, dynamic closure fire endurance, and hose stream.



### UL555S

This test standard governs smoke and combination fire smoke dampers which are intended to prevent the spread of smoke when HVAC systems shut down during a fire emergency and those which control the movement of smoke within building when the HVAC systems functions in smoke control mode. Leakage rated dampers are intended for installation in accordance with NFPA 90A. Side testing includes cycling, salt spray, dust loading, temperature degradation, operation while under heated airflow, and elevated temperature leakage.



### AMCA

IGC is a member of AMCA and all of our products are under process to get Certification from AMCA.



## IGC Aire Dampers

- Commercial Control
- Backdraft
- Manual Balancing
- Barometric Relief
- Fire, Smoke, & Combination Fire Smoke
- Pressure Relief Dampers
- Access Doors

## About Us

IGC manages a sophisticated, global network of independent distributors, sales agents, assembly programs, technology agreements and offshore manufacturing for each product division. All locations are staffed with expert engineers and sales professionals who understand the unique requirements of each market. Our products are on the cutting edge of technology. Research and development is a way of life. We are constantly looking for ways to improve current products and introducing new products to satisfy our ever-changing business environment. Quality is built into all of our products. Statistical process control systems incorporate state-of-the-art computerized data gathering technology to assure performance and measure dimensional accuracy of each component. The finished product, in many instances, exceeds accepted standards, local codes or customer specifications. The combination of an established global network, state-of-the-art products, constant research and development, and built-in quality has placed us ahead of our competition. We are committed to our customers - we are service, we are quality, we are price. A team dedicated to solving customer problems and providing satisfaction.