

# FIRE DAMPERS

**FD-10 STATIC FIRE DAMPER**

**DFD-10 DYNAMIC FIRE DAMPER**

**UL555 1 ½ HOUR RATING**



**IRAN**  
**IGGC**  
IGC International Group

# FD/DFD-10 DESIGN & CONSTRUCTION FEATURES



## Description

Model FD/DFD-10 is a fire damper approved for installation in walls with a fire resistance rating of less than 3 hours. This damper installed vertically in HVAC systems that automatically shut down in the event of fire.

## Construction

- Frame:  
Roll formed, galvanized steel
- Blades:  
Low profile roll formed, galvanized steel

## Features

- Stainless steel closure springs
- Fusible link (165°F (74°C) standard)
- Vertical Mount

## Optional Features

- Sealed transitions and sleeves
- One piece retaining angle (POC)
- Transitions (A, B, C, & CR)

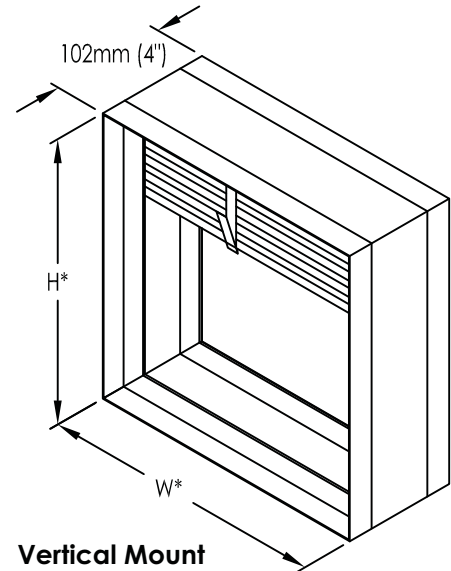

## Factory Sleeve Option

Fire Dampers are available in factory furnished sleeves. Sleeves are galvanized steel and are available in 1.0mm - 1.5mm thicknesses and lengths up to 914mm. "C" dimension specifies location of damper within the sleeve. Minimum is 102 mm; maximum is "L" less 102mm, which allows for mounting angle installation and duct connection at each end of sleeve. If "C" dimension is not specified, it will be provided as one half of "L" dimension (damper centered in sleeve).

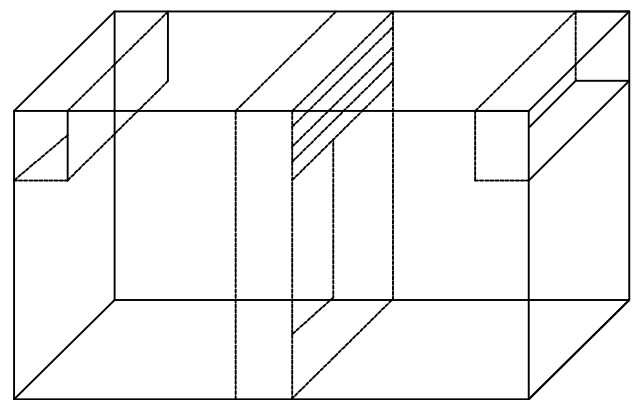
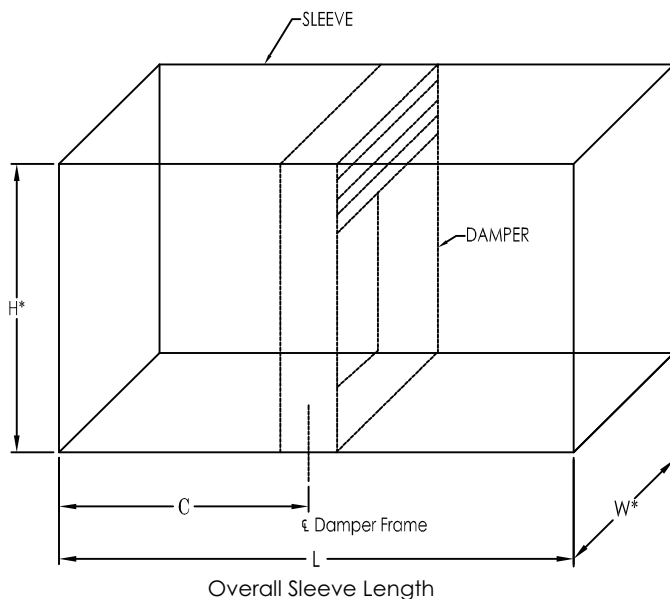

Type B with Sleeve

# FD/DFD-10 TRANSITIONS AND SIZE LIMITATIONS



## Transition Details

TYPE A	
H*	S
102 (4")	20
127 (5")	20
152 (6")	23
178 (7")	28
203 (8")	30
229 (9")	33
254 (10")	33
279 (11")	36
305 (12")	41
330 (13")	43
356 (14")	46
381 (15")	46
406 (16")	51
432 (17")	53
457 (18")	56
483 (19")	58
508 (20")	61
533 (21")	66
559 (22")	66
584 (23")	69
610 (24")	74
635 (25")	79
660 (26")	81
686 (27")	81
711 (28")	84
737 (29")	86
762 (30")	91
787 (31")	94
813 (32")	94
838 (33")	99
864 (34")	99
889 (35")	104
914 (36")	107

TYPE B	
H1*	H2*
102 (4")	152 (6")
127 (5")	178 (7")
152 (6")	203 (8")
178 (7")	229 (9")
203 (8")	254 (10")
229 (9")	279 (11")
254 (10")	305 (12")
279 (11")	330 (13")
305 (12")	356 (14")
330 (13")	381 (15")
356 (14")	406 (16")
381 (15")	457 (18")
406 (16")	483 (19")
432 (17")	508 (20")
457 (18")	533 (21")
483 (19")	559 (22")
508 (20")	584 (23")
533 (21")	610 (24")
559 (22")	660 (26")
584 (23")	686 (27")
610 (24")	711 (28")
635 (25")	737 (29")
660 (26")	762 (30")
686 (27")	787 (31")
711 (28")	813 (32")
737 (29")	838 (33")
762 (30")	864 (34")
787 (31")	889 (35")
813 (32")	914 (36")

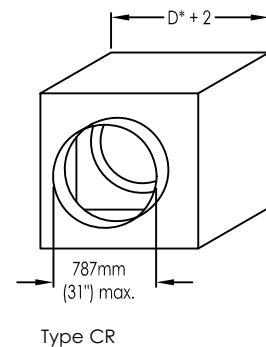
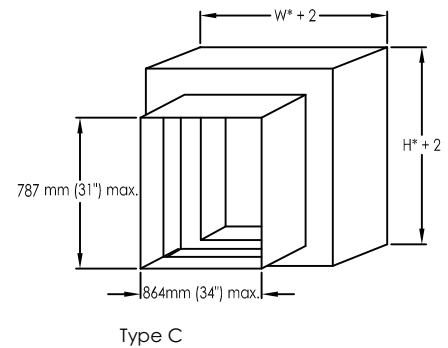
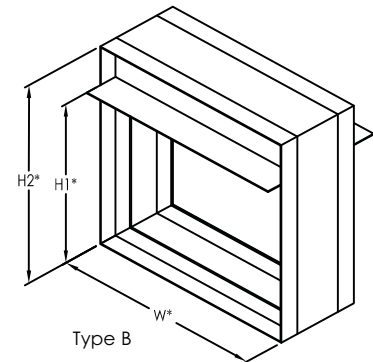
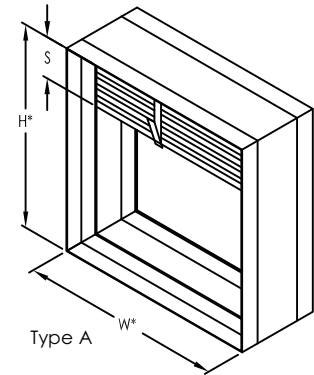

## Size Limitations

VERTICAL SINGLE SECTION SIZE W X H, in (mm)				
TYPE	A	B	C	CR
MINIMUM	4" x 4" (102 x 102)	4" x 4" (102 x 102)	3" x 3" (76 x 76)	3" (76)
MAXIMUM	36" x 36" (914 x 914)	36" x 32" (914 x 813)	34" x 31" (864 x 787)	31" (787)

# FD/DFD-10 OPTIONS AND ACCESSORIES INSTALLATION



## Gauges and Lengths of Fire Damper Sleeve

All fire dampers must be installed in a steel sleeve of the required gauge and length. See table below for required minimum sleeve gauges. Maximum sleeve thickness is 10 gauge (3.5mm). Sleeve inside dimensions must equal damper outside dimensions. Sleeves shall extend a maximum of 6 in. (152mm) beyond the wall opening on each side (see Figure 1).

Sleeve Gauge	Duct Dimension	Types of Duct to Sleeve Connections Permitted
14 Ga. - 10 Ga. (2 mm - 3.5 mm)	All duct sizes	Rigid or Breakaway
16 Ga. 1.5 mm	36 in (914 mm) max. width 24 in (610 mm) max. height 24 in (610 mm) diameter	Rigid or Breakaway
16 Ga. 1.5 mm	All duct sizes	Breakaway only
20 Ga. (0.91 mm)		

Sleeve thickness must not be less than gauge of the connecting duct. UL standard require that all ducts to terminate at fire damper. All sleeve types and thicknesses are needed in the installation instructions is being field supply.

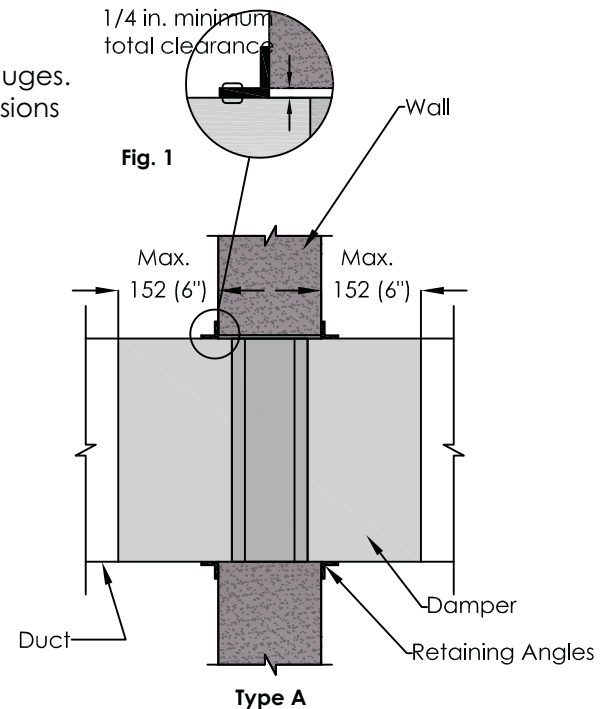

## Attaching Fire Dampers to Sleeves

Fire dampers must be attached to sleeves as shown in Figure 2. All four sides of the damper frame must be attached to the sleeve with one row of attachments on each side of the blade channel. Attachments must be spaced a maximum of 4 in. (102mm) on centers and a maximum of 1 in. (25mm) from corners. A minimum of 4 attachments (2 on each side of the blade channel) per side (16 per damper) are required. One of the methods of attachment shown below must be used.

- tack or spot welds (sleeves thicker than 16 Ga shall not be provided with spot welds).
- #10 sheet metal screws
- 1/4 in. (6mm) bolts and nuts
- 3/16 in. (4.7mm) steel pop rivets

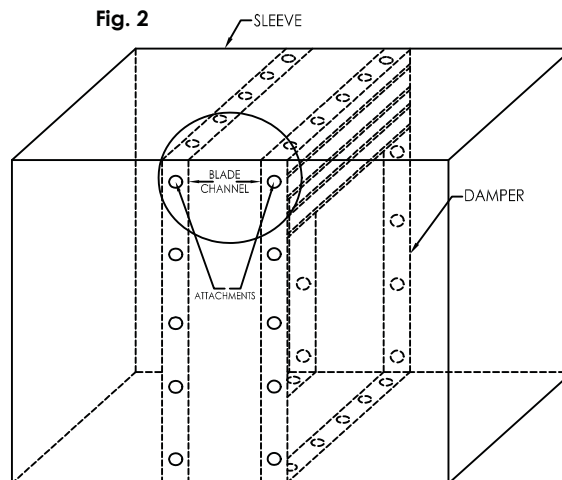

NOTE: ATTACHMENTS MUST NOT ENTER BLADE CHANNEL OR THEY MAY CAUSE INTERFERENCE WITH BLADE CLOSURE.



## Securing Fire Damper and Sleeves to Wall Openings

The fire damper must be installed such that the centerline of the blades are mounted in the plane of the wall. Fire damper and sleeve assemblies must be installed in wall openings using retaining angles on each side of the wall as described below:

- Retaining angles for 1 ½ hour rated dampers with a height 36 in. (914 mm) or less must be a minimum of 16 ga. (1.5 mm). The leg of the retaining angle on the damper sleeve shall be a minimum of 2 in. (51mm). The leg of the retaining angle on the wall shall be long enough to cover the annular space and overlap the wall by a minimum of 1 in. (25mm). (See Figure 3). Retaining angle legs may be reversed with leg of retaining angle with annular space of opening so angle and sleeve is flush against barrier.

- Retaining angles shall not be attached to the sleeve with tack, spot weld or rivets. 3/4 x 10 screws and 1 x 10 bolts and nuts. The corners shall be attached at the corners with one rivet.

- Retaining angles should not be fastened to the wall material. The angles should only sandwich the wall and allow for damper/sleeve expansion during periods of intense heat.

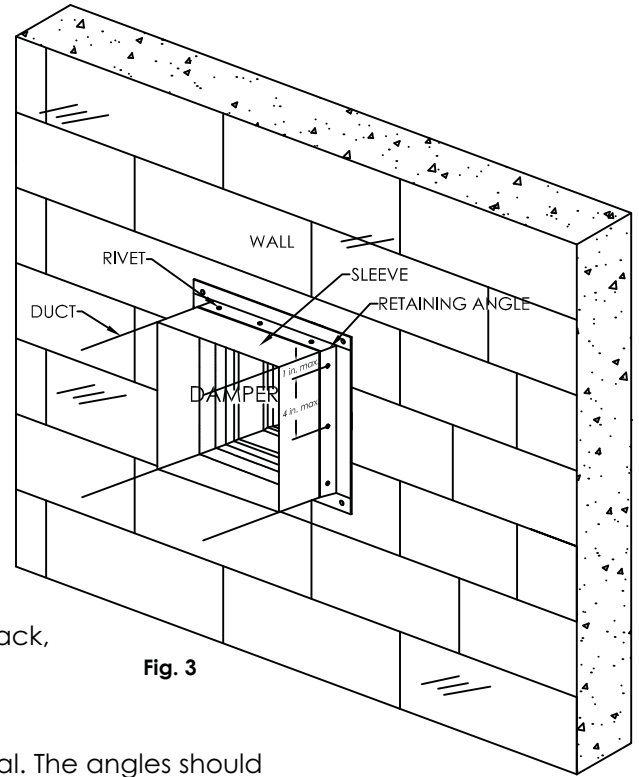

Fig. 3

## Connecting Ducts to Fire Damper Sleeve

Any duct connection other than breakaway is considered rigid. The connections shown are considered breakaway. Factory furnished duct collars on type R and CR fire dampers are also considered breakaway.

### Duct-Sleeve Connections

#### Traditional Breakaway Style Transverse Joints

Transverse joints illustrated have always been approved as breakaway connections. SMACNA testing has also approved the following variations as breakaway connections. Breakaway connections shall have no more than two #10 (4.8mm diameter) sheet metal screws on each side and on the bottom located in the center of the slip pocket and shall penetrate both sides of the slip pocket (applicable to the Plain "S" Slip and Hemmed "S" Joint). Transverse joint can be applied as top and bottom joints with Drive Slip – side joints in duct heights up to 20 in. (508mm)

Plain "S" Slip	
Drive Slip Joint	
Hemmed "S" Slip Joint	

## Test Standard & Certification

### UL555

This test standard governs fire dampers which are intended for use where air ducts penetrate or terminate at openings in walls or partitions, in air transfer openings in partitions, and where air ducts extend through floors as specified in the Standard for Installation of Air-Conditioning and Ventilating Systems, NFPA 90A. In a fire emergency the damper is designed to close and prevent the spread of fire from one side of the wall or partition to the other. Side testing includes cycling, salt spray, dust loading, dynamic closure fire endurance, and hose stream.



## IGC Aire Dampers

- Commercial Control
- Fire, Smoke, & Combination Fire Smoke
- Backdraft
- Pressure Relief Dampers
- Manual Balancing
- Access Doors
- Barometric Relief

## About Us

IGC manages a sophisticated, global network of independent distributors, sales agents, assembly programs, technology agreements and offshore manufacturing for each product division. All locations are staffed with expert engineers and sales professionals who understand the unique requirements of each market. Our products are on the cutting edge of technology. Research and development is a way of life. We are constantly looking for ways to improve current products and introducing new products to satisfy our ever-changing business environment. Quality is built into all of our products. Statistical process control systems incorporate state-of-the-art computerized data gathering technology to assure performance and measure dimensional accuracy of each component. The finished product, in many instances, exceeds accepted standards, local codes or customer specifications. The combination of an established global network, state-of-the-art products, constant research and development, and built-in quality has placed us ahead of our competition. We are committed to our customers \_ we are service, we are quality, we are price. A team dedicated to solving customer problems and providing satisfaction.